



FEATURE

A highly versatile series of surface mountable 14.7 x 9.2 x 6.2mm oscillators (VCXOs) for applications where small size and high performance are prerequisites. This oscillator uses CIMAKE's latest custom ASIC "Pluto", a single chip oscillator and analogue compensation circuit, capable of sub 0.3 ppm performance. Its wide frequency range, operating temperature range, drive capability, coupled with its high stability and linear frequency pulling make it the ideal reference oscillator. Its ability to function down to a supply voltage of 2.4V and low power consumption makes it particularly suitable for mobile applications.



Specification for electrical appliances

Parameter	3.3V		Unit
	MIN	MAX	
Supply Voltage (VDD) 5%	3.135	3.465	V
Frequency Range	5	1700	MHz
Standard Frequency	122.880000		
Frequency Tolerance*	10.0		ppm
Output waveform	LVPECL		
Supply voltage @Vcc 5%	±1.0		ppm
Load Variation	±1.0		ppm
Ageing(first year)	±1.0		ppm
Temperature Stability	±20		ppm
Operating Current	65		mA
Symmetry @50%	45	55	%
Rise Time/ Fall Time	0.5		ns
Load	15		pf
Control Voltage Range 1.65V	0.3	3	V
Frequency Adjustment Range	±80	±150	ppm
Slope & Linearity	10		%
Operating temperature range	-40	85	° C

page:1



122.880Mhz SMK9014 ssp phase noise

Phase Noise		Unit
10Hz	-73	dBc/Hz
100Hz	-100	
1KHz	-125	
10KHz	-145	
100KHZ	-150	

Environmental Parameters

Storage Temperature Range: -55 to 125°C

Frequency stability over temperature in still air

Shock: IEC 60068-2-27, Test Ea: 1500G acceleration for 6ms, 3

shocks in each of 3 mutually perpendicular planes

Vibration: IEC 60068-2-6, Test Fc, Procedure B4: 10Hz-60Hz, 1.5mm

displacement, 60-2000Hz at 98.1m/s², 30mins in 3 mutually

perpendicular planes at 1 oct/min

Solderability: MIL-STD-202, Method 208, Category 3

Pad Functions and Package Dimensions (in mm)

- 1PIN Control Voltage
- 2PIN E/D
- 3PIN GND
- 4PIN Output
- 5PIN Complementary Out
- 6PIN Vcc

DIMENSION (mm)

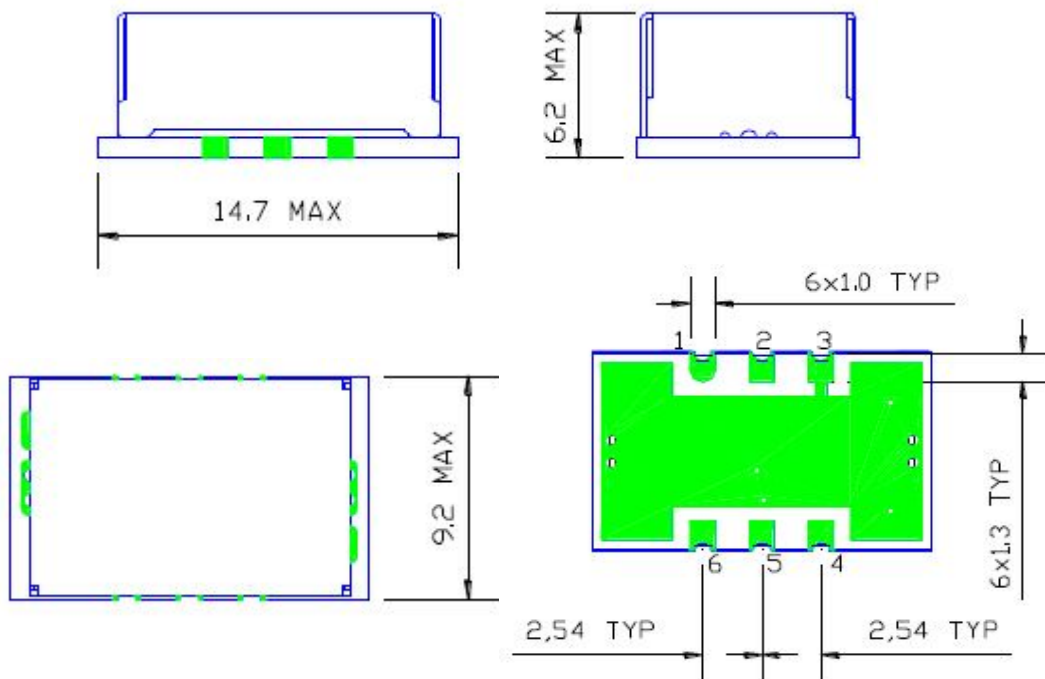

Solder Pad Layout

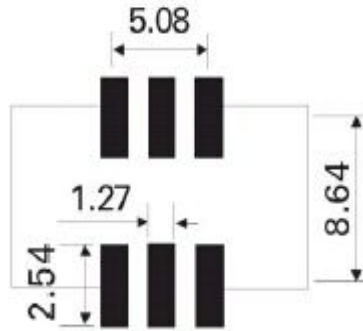

Test Circuit

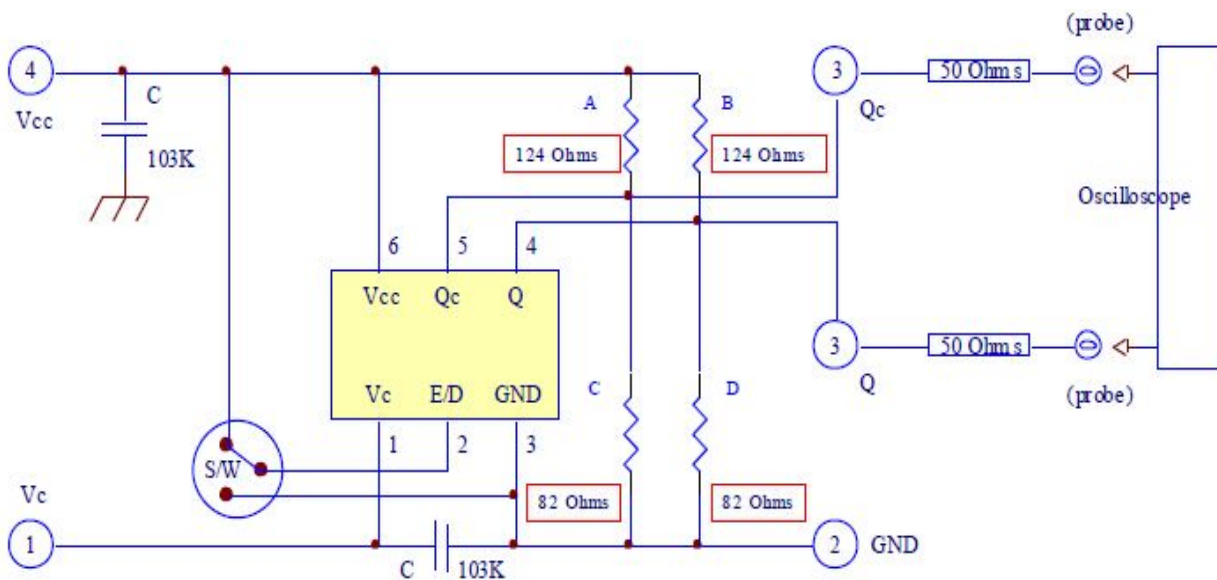

Output Waveform

