



## FEATURE

The SMK52520CAI belongs to a range of super single oven OCXOs designed as a compact and smart frequency source and time keeping reference for all synchronization systems, including precision positioning system bases equipment.

52\*52\*19 mm

## Applications

- Stratum 2 timing modules
- Time and frequency references
- Wireless Base Stations ( GSM, UMTS, CDMA, LTE)
- Instrumentation and Broadcasting



## Specification for electrical appliances

Parameter	5.0V		12V		Unit
	MIN	MAX	MIN	MAX	
Supply Voltage(VDD) 5%	4.75	5.25	11.4	12.6	V
Frequency Range	5	15	5	15	MHz
Standard Frequency	10	12.8	13	15	
Frequency Tolerance*	±0.2		±0.2		ppb
Vs Load (±10%) change	±10		±10		
Vs Aging	±10		±10		
Power consumption	8		8		W
	3.5		3.5		W
Supply voltage stability	±0.05		±0.05		ppb
Output Level (CMOS)					
Output voltage level high (VOH)	2.4		2.4		V
Output voltage level low (VOL)	0.4		0.4		
Rise & fall time	5		5		ns
Duty	45	55	45	55	%
Start-up time	1		1		sec
Short term 1s to 10s integration time	±0.002		±0.002		ppb
Vc Input Impedance	100		100		KΩ
Operating temperature range	-40	85	-40	85	° C

EMAIL: EVA@CIMAKE.COM.CN    MARK@CIMAKE.CO.UK

TEL: +44 0208 492 6388

FAX: +44 0208 492 0196

COMPANY ADDRESS: 419, HARBOME ROAD , EDGBASTON, BIRMING.B15 3LB



10.00Mhz SMK52520CAI ocxo ssp phase noise

Phase Noise		Unit
10Hz	-140	dBc/Hz
100Hz	-155	
1KHz	-160	
10KHz	-165	

**Environmental Parameters**

Storage Temperature Range: -55 to 90° C

Frequency stability over temperature in still air

Shock: IEC 60068-2-27, Test Ea: 1500G acceleration for 6ms, 3 shocks in each of 3 mutually perpendicular planes

Vibration: IEC 60068-2-6, Test Fc, Procedure B4: 10Hz-60Hz, 1.5mm displacement, 60-2000Hz at 98.1m/s<sup>2</sup>, 30mins in 3 mutually perpendicular planes at 1 oct/min

Solderability: MIL-STD-202, Method 208, Category 3

**DIMENSION (mm)**

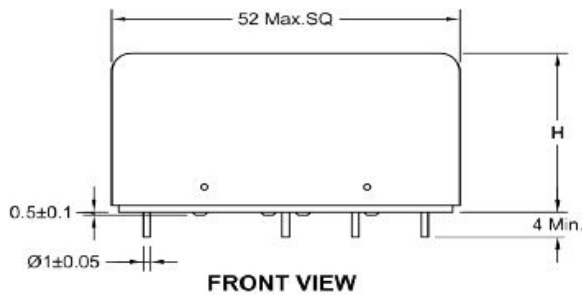

**HEIGHT (H) OPTIONS:**

- H = 19.0 mm, or
- H = 25.4 mm.

**NOTE:**

Outline unit is mm.  
Tolerance is ± 0.2mm if it has not been indicated.

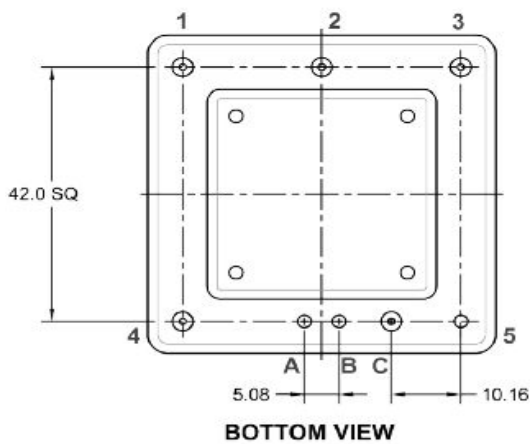

**PIN CONNECTIONS**

- 1 Vc (Frequency Control)
- 2 VREF (Reference Voltage)
- 3 Output (Output Signal)
- 4 GND
- 5 Vcc (Power Supply)
- A Do Not Connect (For Internal Use)
- B Do Not Connect (For Internal Use)
- C Optional

EMAIL: EVA@CIMAKE.COM.CN MARK@CIMAKE.CO.UK

TEL: +44 0208 492 6388

FAX: +44 0208 492 0196

COMPANY ADDRESS: 419, HARBOME ROAD , EDGBASTON, BIRMING.B15 3LB